

The Smoother™ Installation Instructions

Description

The Smoother heat balancing circulator control distributes heat evenly throughout all radiators in a single-zone hot-water heating system. The temperature variations between radiators associated with temperature-switch circulator controls are eliminated, while pump noise and electricity usage are reduced compared to a continuously running circulator. The all-solid-state circulator control circuit incorporates a soft-start that reduces the noise and stress of pump start. It is compatible with all single-phase 120v circulators, including wet- and dry-rotor types. A circulator-exercise feature helps prevent circulator seizing during the summer months. An LED shows proper unit function and flashes to indicate the setting selected.

Features and Benefits of the Smoother

- **Distributes heat evenly to all radiators**
 - no more cold radiators in outlying rooms
 - prevents overheated rads close to boiler
- **Approximately 75% less electricity consumption and pump noise than continuous circulation.**
- **Circulator-exercise feature helps prevent seizing during summer months.**
- **Helps to reduce system overheating in mild weather.**
- **Prevents thermal shock of cold water entering hot boiler, and reduces thermal cycling, extending boiler life**
- **Works with gas, oil, or electric boilers.**
- **Easy installation - no plumbing or temperature sensors, plug-in terminal blocks.**
- **All solid-state design for maximum reliability**
- **Easy setting. Set once - never needs adjustment, regardless of season**
- **Non-volatile memory stores the setting during shut-down**

Applications

- For use with new or existing residential boilers with 24vac thermostat circuit.
- For traditional single-zone, single-pump systems.
- The neutral terminal of the 24VAC transformer must be accessible--Some oil-burner controls are not.
- Not recommended for boilers with integrated domestic hot water supply
- The circulator switch is not fused: the circulator must have its own overload protection.

Performance Specifications

- Operating humidity: 5% – 95% non-condensing
- Ambient operating temperature: 0° to 45°C
- Thermostat circuit 24 VAC
- Circulator switch contact max 1/4hp or 8A continuous, 120 VAC

Installation

When Installing this Product

1. Read these instructions carefully. Failure to follow them could damage the product or cause a hazardous condition.
2. Check the ratings given in the instructions and on the product to make sure the product is suitable for your application.
3. Installer must be a trained, experienced service technician.
4. After installation is complete, check out product operation as provided in these instructions.
5. Follow local codes for installation and application.

CAUTION



Electrical Shock or Equipment Damage Hazard: can injure or kill individuals, or short equipment circuitry.

Disconnect all power supplies before installation.

- All wiring must comply with applicable local codes, ordinances and regulations. Refer to **Fig. 1** for typical wiring diagram. Route wiring carefully to avoid pinching wires when reinstalling the cover.
- Follow boiler manufacturer's instructions regarding proper bypass, if needed, to prevent condensation. A boiler bypass gives better heat distribution than a system bypass, however in all cases follow manufacturer's instructions.
- **Important:** Use a maximum of 14 AWG wire for wiring terminals. Pump Circuit wiring must be rated for 300 V.

Location

Locate the Smoother on the sheet-metal exterior of the boiler's wiring vestibule, close to the boiler's thermostat terminals and circulator connection. Make sure the location is accessible for installation and service and that the ambient temperature at the selected location does not exceed 110°F (45°C).

Note: Ensure that drill and mounting screws will not interfere with wires or components inside the boiler.

Mounting

1. **Securely shut off all power to the boiler, circulator, and any auxiliary equipment.**
2. Position the control at the selected location and mark the mounting holes.
3. Mount unit using two #8 sheet metal screws. Be careful not to damage the circuit board or components during drilling or mounting.

Wiring

1. **Ensure all power sources are securely shut off.**
2. Disconnect the circulator from any other control relay (low-limit, relay, etc.). NOTE: DO NOT disable or bypass the High-Limit safety shutdown, or any other safety circuits.
3. **Wiring - as shown in Fig.1**
4. Unplug the terminal blocks from the circuit board for easier connection.
5. Terminal 1 must be grounded.
6. Terminals 2 and 3 are the poles of the circulator switch. Connect them in series with the 120V line to the circulator, as shown. They may be reversed without affecting operation.
7. Terminal 4 connects to the neutral pole of the 24vac transformer. This pole of the transformer may be identifiable by a grounding wire. On some boilers, neither pole is grounded (floating common). In this case, the soft-start feature is automatically disabled.
8. Terminals 5 and 6 (R / W) tie in with the 24v thermostat where it is connected to the boiler, as shown in **Fig.1**. These terminals may be reversed without affecting operation.
9. Plug the terminal blocks back into the circuit board.
10. Set the CIRC selector switch for either DRY or WET rotor circulator: see below.

Setting the CIRC. Switch: CAN ONLY BE CHANGED WITH POWER OFF

This switch enables or disables the Soft-Start feature. Set it according to the type of circulator used.

WET-rotor pumps use a standard hard-start – switch pushed UP / on.

DRY-rotor pumps use the soft start - switch pushed DOWN / off.

Power-Up and Test

Proper function can be tested as follows:

1. Verify all wiring connections, adjust the thermostat so it is not calling for heat, and turn on power to the system.
2. The green LED should be flashing briefly every couple of seconds.
3. If the LED remains dark, verify wiring to terminals 4, 5, and 6.
4. Turn the thermostat ON (call for heat)
5. The LED will come on continuously, and the pump will start.
6. Turn OFF the thermostat. The burner will shut off, but the pump will continue running
7. If any part of the sequence fails, verify the wiring, and consult the Troubleshooting section

FIG.1 Installation Wiring Diagram

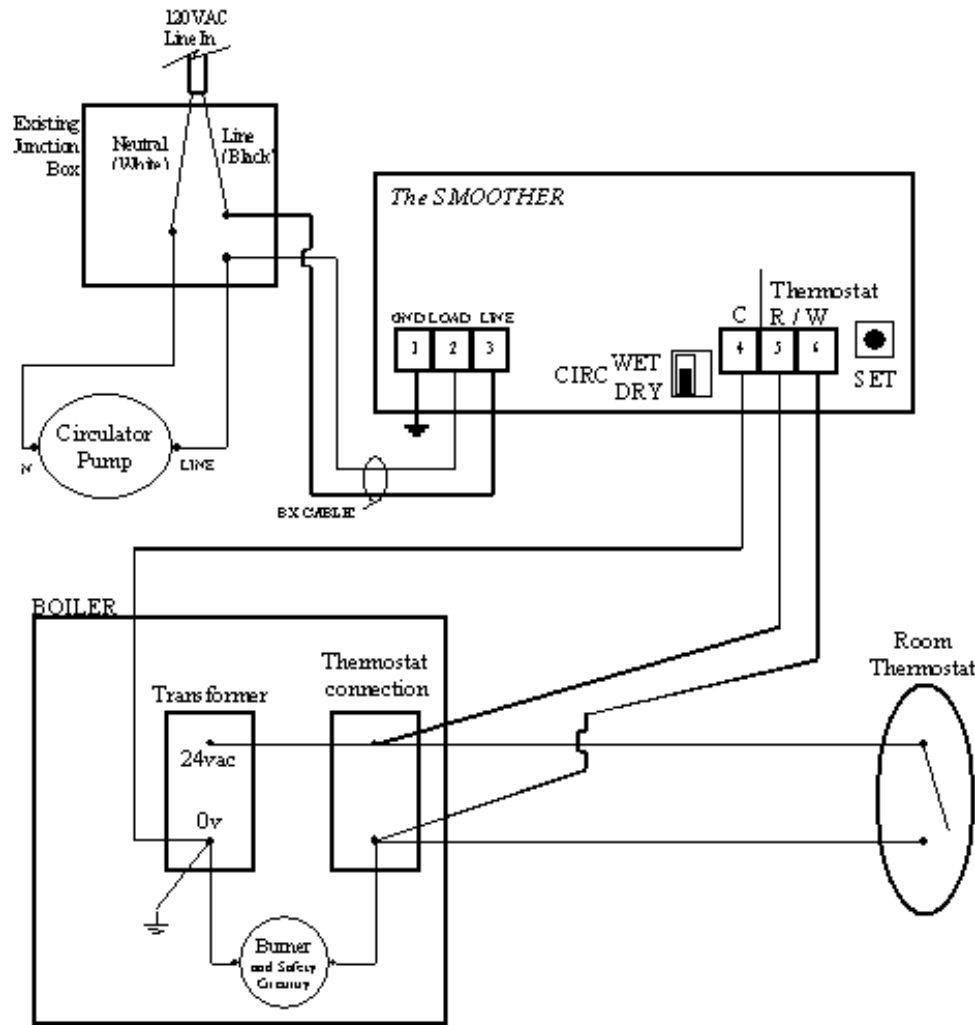

Adjusting the Setting

The setting determines how much extra circulator operating time the Smoother will give the circulator. The correct setting depends primarily on the type of radiators in the home.

- A home with all cast iron radiators (high heat capacity) will take setting 1 or 2, while a home with baseboard-type radiators (low heat capacity) will take setting 2 or 3. Homes with a mixture of cast-iron and baseboards require a higher setting, 3 or 4.
- If the circulator is very small, the plumbing is old or corroded, or the house is very large, then use the higher of the two recommended settings. Otherwise, start with the lower setting.
- Settings five and six are only for systems with very low water flow in one or more radiators, due to serious sediment or corrosion, stuck valves, or other problems.
- The LED on the top of the unit will flash to indicate the setting.

Setting	LED Flashes	Running Minutes*	Recommended for radiator type:		
			Cast Iron	Baseboard	Mixed
1	1	4	✓		
2	2	7	✓	✓	
3	3	11		✓	✓
4	4	16			✓
5	5	25	For badly corroded pipes, severe flow problems - try lower settings first		
6	6	1 hour			

*minutes of extra circulator running after burner shut-off

CAUTION

⚠ During setting, the pump circuit (terminals 1, 2, and 3 and circuit board components) are live at 120VAC. DO NOT TOUCH ANYTHING except the SET button while unit is energized!

Changing The Setting:

1. Ensure the thermostat is OFF (not calling for heat). If the circulator is running (LED is ON continuously) press the SET button once to reset.
2. Press the SET button to advance the setting. The LED will flash the new setting.
3. After 6, the setting rolls back to 1.
4. The setting is not cleared by cycling power to the unit. It will remember its setting even after a shutdown.

TROUBLESHOOTING

LED Status:

- 1) OFF Continuously: No power to control circuitry. Verify wiring to terminals 4, 5, and 6
- 2) Repeating pattern of between 1 and 6 flashes: normal operation, number of flashes indicates setting.
- 3) ON Continuously: The thermostat is calling for heat, or the pump is still running after a call for heat.

Problem: The unit does not respond to a thermostat call for heat.

Solution: Verify wiring of terminals 4, 5, and 6. Follow the diagram in Fig.1

Problem: The LED shuts OFF completely when the thermostat calls for heat

Solution: Terminal 4 (C) is connected to the wrong pole of the transformer. Attach to other pole.

Problem: When the burner fires, the LED comes on continuously but the pump does not start.

Solution: Verify wiring of terminals 2 and 3. Terminal 3 (LINE) must be directly connected to 120v line, not through any other control relays. Terminal 2 should go directly to the 120V line-in of the pump.

LIMITED 2 YEAR WARRANTY

New Current Inc. warrants this product to be free from defects in materials and workmanship for two years from the date of purchase. Any in-warranty defective product should be returned to the point of purchase with sales receipt. This warranty is limited to the electronic circuitry and original casing of the product and specifically excludes damage caused by abuse, unreasonable use or neglect. This warranty is in lieu of all other warranties, express or implied, and no other representations or claims of any nature shall bind or obligate New Current Inc. Any implied warranties applicable to this product are limited to the two year period following its purchase. IN NO EVENT WILL NEW CURRENT INC. BE LIABLE FOR ANY SPECIAL, INCIDENTAL OR CONSEQUENTIAL DAMAGES RESULTING FROM POSSESSION, USE OR MALFUNCTION OF THIS PRODUCT.

For more information: visit www.thesmoother.com, www.newcurrent.com or contact New Current Inc. at 416-703-7683 e-mail: customerservice@newcurrent.com ©2005 New Current Inc.